



**PRODUCT
CATALOG**



MACHINES FOR
WOOD
& **PALLET**
INDUSTRY

AUTOMATIC CABLE DRUM FLANGE NAILING AND PRODUCTION LINES
FMCIH 600-1800 / 800-2500 / 1000-3200

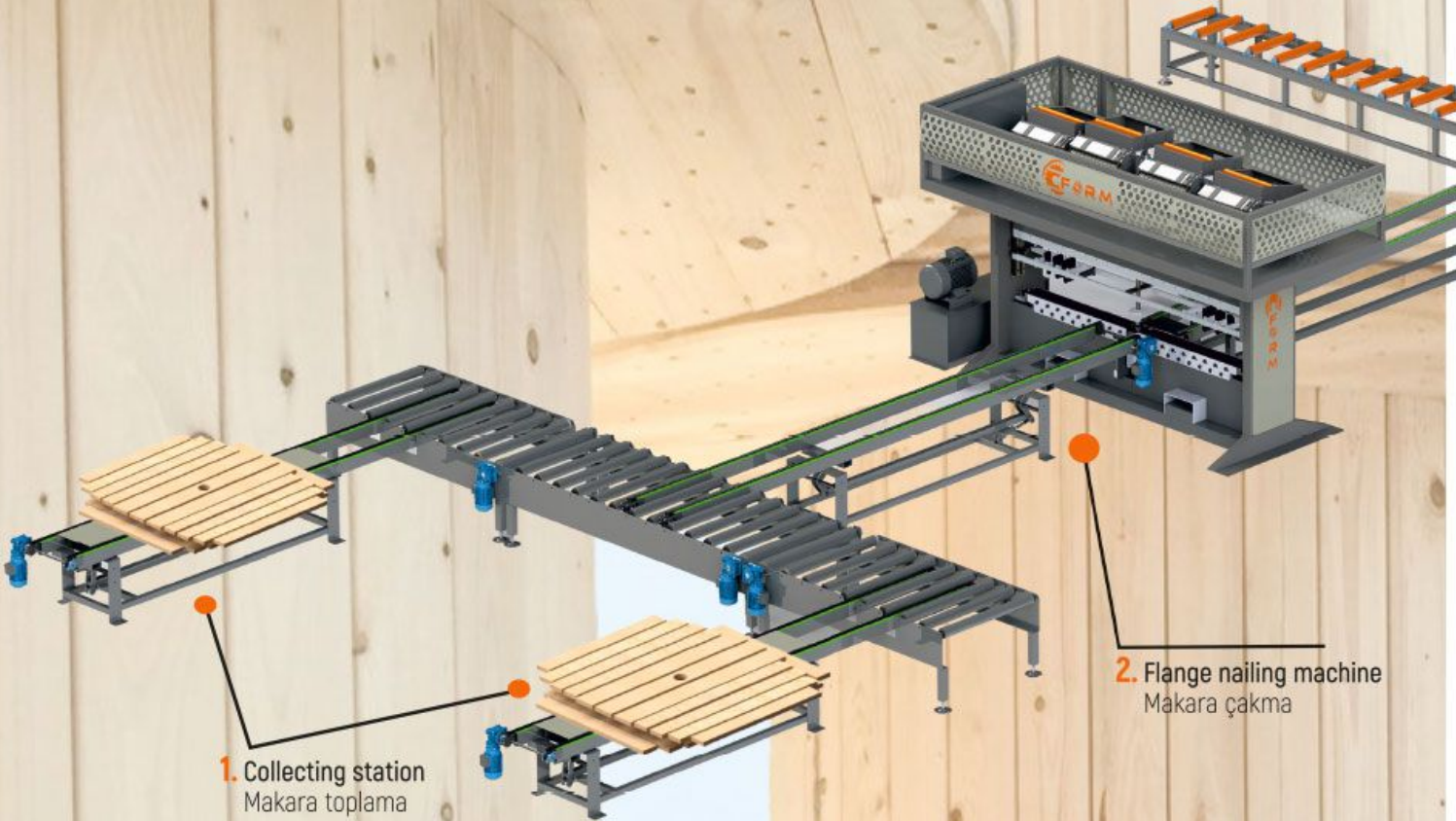

Nailing Machine / Çakım Makinesi



CABLE DRUM NAILING & PROCESSING LINE MAKARA ÇAKIM & İŞLEME HATTI

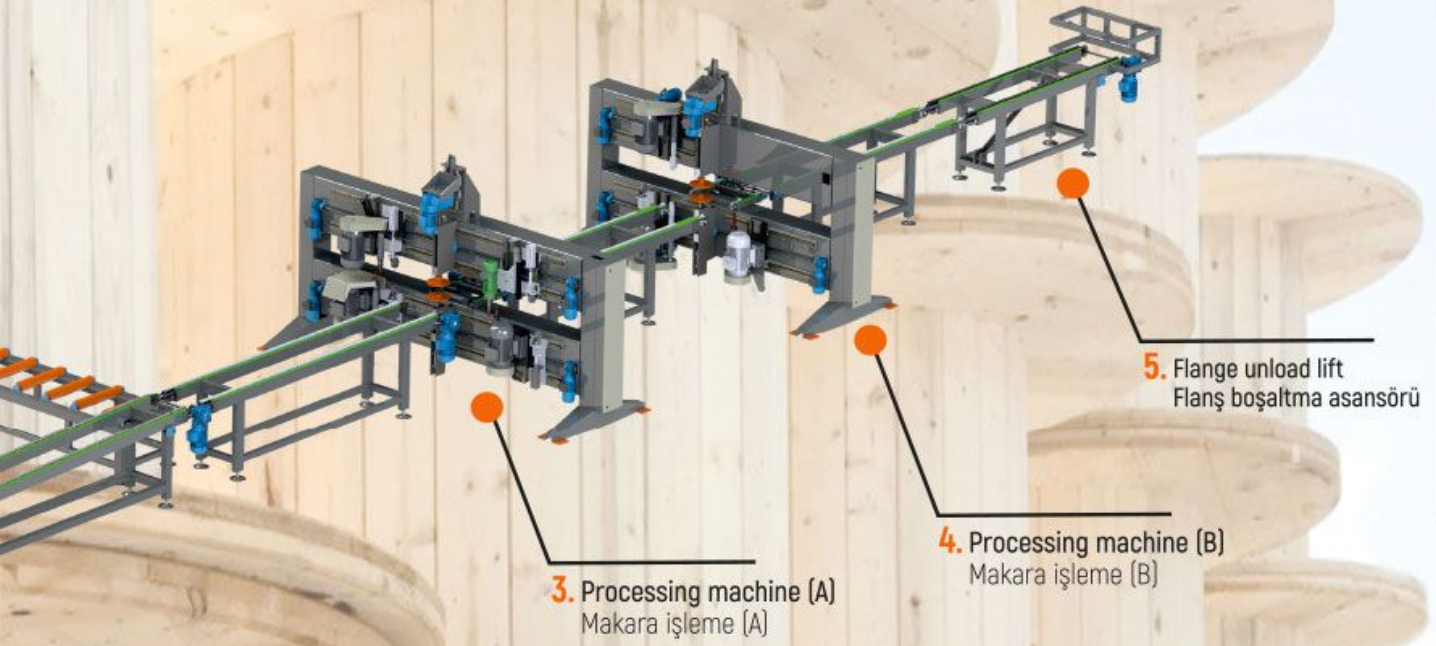

NAILING MACHINE FOR CABLE DRUM FLANGES.

- ▶ **FMCIH 600-1800** (FOR DIAMETER 600-1800 mm)
- ▶ **FMCIH 800-2500** (FOR DIAMETER 800-2500 mm)
- ▶ **FMCIH 1000-3200** (FOR DIAMETER 1000-3200 mm)

PROCESSING TERMINAL FOR CABLE DRUM FLANGES

- ▶ **FMI 600-1800** (FOR DIAMETER 600-1800 mm)
- ▶ **FMI 800-2500** (FOR DIAMETER 800-2500 mm)
- ▶ **FMI 1000-3200** (FOR DIAMETER 1000-3200 mm)

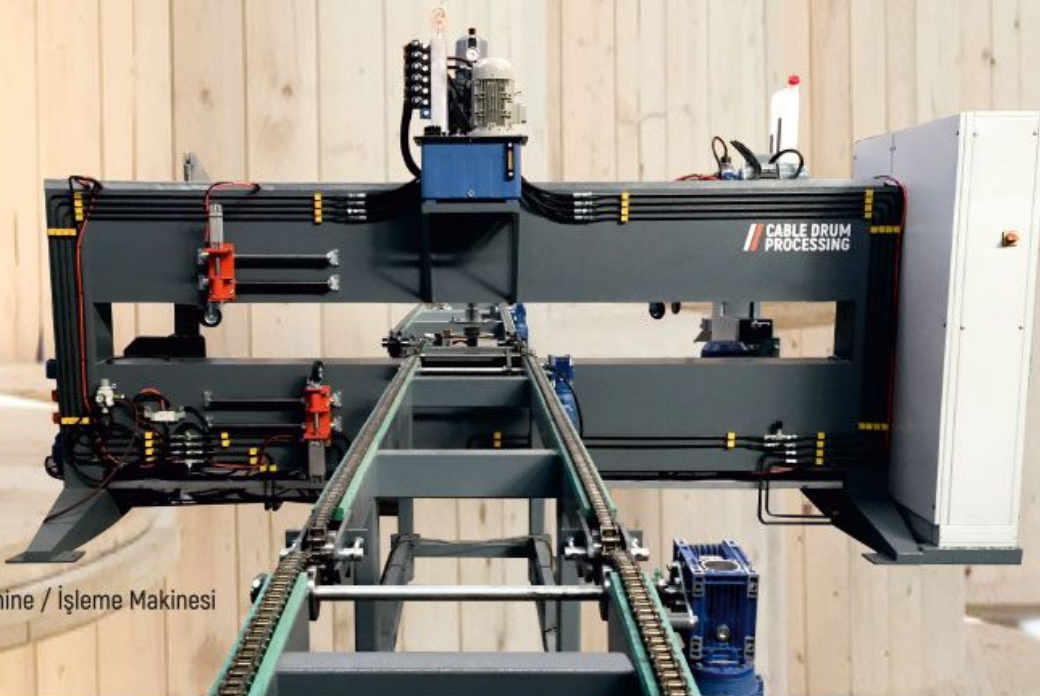

Processing Machine / İşleme Makinesi

